

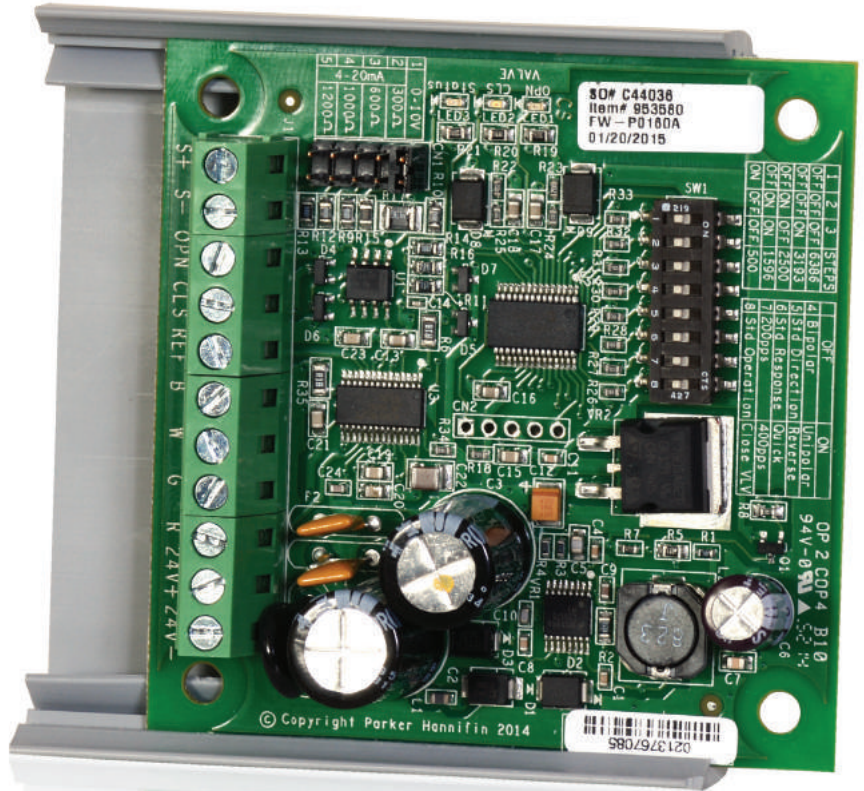

SPORLAN

Sporlan IB-G Interface Board

Installation and Operation Instructions



Contents

1. Installation	3
2. Setup	4
3. System Operation.....	4
4. Troubleshooting	5
APPENDIX A	
Ordering	7
APPENDIX B	
Technical Specs	7
APPENDIX C	
Wiring Diagram.....	8

⚠WARNING – USER RESPONSIBILITY

Failure or improper selection or improper use of the products described herein or related items can cause death, personal injury and property damage.

This document and other information from Parker Hannifin Corporation, its subsidiaries and authorized distributors provide product or system options for further investigation by users having technical expertise.

The user, through its own analysis and testing, is solely responsible for making the final selection of the system and components and assuring that all performance, endurance, maintenance, safety and warning requirements of the application are met. The user must analyze all aspects of the application, follow applicable industry standards, and follow the information concerning the product in the current product catalog and in any other materials provided from Parker or its subsidiaries or authorized distributors.

To the extent that Parker or its subsidiaries or authorized distributors provide component or system options based upon data or specifications provided by the user, the user is responsible for determining that such data and specifications are suitable and sufficient for all applications and reasonably foreseeable uses of the components or systems.

For safety information see the Safety Guide at www.parker.com/safety or call 1-800-CParker.

OFFER OF SALE

The items described in this document are hereby offered for sale by Parker Hannifin Corporation, its subsidiaries or its authorized distributors. This offer and its acceptance are governed by the provisions stated in the detailed "Offer of Sale" available at www.parker.com.

FOR USE ON REFRIGERATION and/or AIR CONDITIONING SYSTEMS ONLY

For more information about our products visit us at www.sporlan.com.

Bulletin 100-50-2.1 August 2016, supersedes Bulletin 100-50-2 July 2014, and all prior publications.



Introduction

The **IB-G** is a small electronic circuit board that extends the functionality of an external system controller to drive step motor valves. The external controller must provide an analog 0-10VDC or 4-20mA signal to the IB-G. The signal is then converted to a step motor signal to position the valve.

The IB-G has been developed with all of the functionality of the following IB Series Interface Boards including quick response versions: IB 1, IB 2, IB 3, IB 6 and IB ESX. All of these options are configurable on the IB-G. The IB-G can accept 4-20 milliamp or 0-10 volt DC analog input signals and is designed to allow externally supplied control signals to control one or two Sporlan step motor valves including CDS evaporator control valves, SDR electric discharge bypass valves, and SEI/SER/SEH/SEV/ESX* electric expansion valves. Enhanced features include LED indicators for power and valve position, option for 400 pulses per second (pps), and a valve open or close feature.

*The IB-G can only control a single ESX valve.

1. Installation

TOOLS REQUIRED:

- Small flat screwdriver for terminal connections
- Phillips and flat screwdrivers
- Cordless screwdriver
- Needle-nose pliers
- Wire cutters
- Two #8 x 1/2" self-tapping screws to mount SNAP Track

1. Mount the IB-G in a dry, protected location close* to the 24 volt power supply and external controller. The IB-G is based on a 3.0" x 3.0" (76mm x 76mm) circuit card with 0.170" (4.3mm) mounting holes located at each corner, 2.5" (63.5mm) center-to-center. If desired, these mounting holes may be used with customer supplied non-metallic standoffs. The IB-G is supplied with a length of snap-in plastic track. The track should be mounted in the desired location with the orientation shown in *Figure 1*. Note that the track should be at the top and bottom. Place the board into the bottom track and then snap the top of the board into the upper track. Only press on the PCB top edge during installation, do not press on components or the center of the PCB. The screw terminals should be located on the left when facing the IB-G. See *Figure 1*.



Warning: Do not apply power to the IB-G until wiring is complete. Remove power before making any wiring changes.

*Voltage drop must be considered when locating the IB-G away from the power supply and external controller.

2. Digital inputs connected to terminals “OPN”, “CLS” and “REF” can be used to drive the valve open or closed. A short between “OPN” and “REF” will open the valve 100%, a short between “CLS” and “REF” will close the valve. The “OPN”, “CLS” and “REF” terminals, if used, must be supplied with a “dry” contact from a switch or relay. No external power should be applied to these terminals. See *Figure 1*.
3. Connect valve wires to terminals “B”, “W”, “G” and “R” (Black, White, Green, Red). See *Appendix C – Wiring Diagram for unipolar valves*.
4. Connect externally supplied control signal (4-20mA or 0-10V) to terminals “S+” and “S-”. See *Figure 1* and *Appendix C – Wiring Diagram*.
5. Connect power wires to terminals “24V+” and “24V-”. Do not power up. The 24 volts must be supplied by a 30 VA or 40 VA, Class II, transformer (depending on the valve type and number of valves per IB-G) not used for any other purpose. In addition, the secondary winding of the transformer must not be connected to chassis ground. A single transformer may be used for multiple IB-G boards. If a single transformer is used, one leg of the 24 volt supply must be connected to all of the IB-G boards at the “24V+” terminal. The other leg of the 24 volt supply must be connected to all of the IB-G boards at the “24V-” terminal. See *Appendix C – Wiring Diagram*.

Notes:

- The 24VAC supply polarity is critical when two IB-Gs are used. See *Appendix C – Wiring Diagram*.
- Maximum torque on all screw terminals is 3.5 in-lbs.

Warning: Route and secure cables away from hot surfaces, high voltage lines, and moving components. Use caution when working around high voltage components. Safety covers should be used for personal safety on high voltage panels.



† See *Appendix C – Wiring Diagram* for unipolar valves.

Figure 1

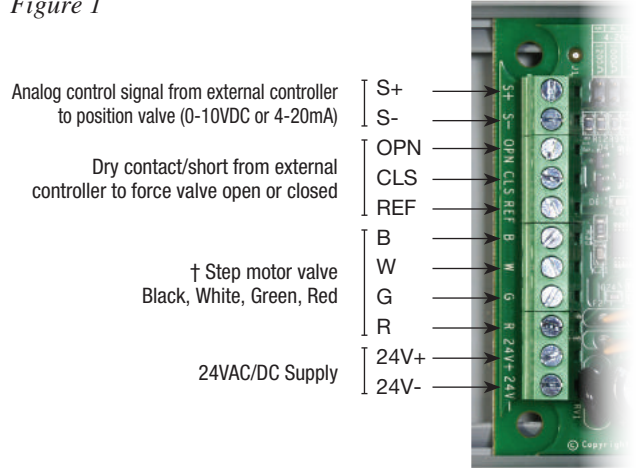

2. Setup

See *Figure 2* for locations of input configurations and DIP switches. With the IB-G unpowered, select the input signal of 0-10V or 4-20mA and desired impedance by installing the supplied jumper to one of the 5 pin locations listed in *Table 1*. Set the DIP switches in accordance with the valve and desired operation listed in *Table 2* and *Table 3*. Each DIP switch is considered “OFF” when the switch is positioned toward the middle of the board. This is the left position in the orientation shown in *Figures 2, 2a*. Default settings are highlighted in yellow.

Warning: Do not apply power to the IB-G until setup is complete, and remove power before making any DIP switch or jumper changes.

Figure 2

Table 1 - Input Signal
(jumper location)

5	4	3	2	1
4-20mA				
1200Ω	1000Ω	600Ω	300Ω	0-10V

Table 2 – Number of Steps

DIP #	6386	3196	2500	1596	500
1	OFF	OFF	OFF	OFF	ON
2	OFF	OFF	ON	ON	OFF
3	OFF	ON	OFF	ON	OFF

Figure 2a

Table 3 – Valve Type/Operation

DIP #	OFF	ON
4	Bipolar	Unipolar
5	Std Direction	Reverse
6	Std Response	Quick
7	200pps	400pps
8	Std Operation	Close Valve

Notes:

The selection of “Unipolar” and “1596” steps will override DIP switch #7 to 200 pps.
 The selection of “Unipolar” and “500” steps will override DIP switch #7 to 30 pps.
 If an invalid valve configuration is set, all 3 LEDs will flash and the valve will not move.

3. System Operation

Normal Valve Operation:

On power-up, the IB-G will initialize by giving the valve a large number of steps to assure that the valve is fully shut. The board will not respond to input signals during this time. This routine will take approximately 30 seconds. After initialization, the board will position the valve based on the control signal provided by the external controller. Note: The DIP switches will override the standard control input. Ensure that the DIP switches are configured properly. Reference sections below for further information. The control signal and valve position have a linear relationship. For example; if the external controller provides 5VDC signal across terminals ‘S+’ and ‘S-’ and the IB-G is set for 0-10V signal, then the valve will be positioned at 50% open; 7.5VDC signal will position the valve at 75% open, etc. To allow for component tolerances, the IB-G will shut the valve when the input signal reaches 4.05 milliamps or 0.05 volts depending on the configuration. If power is lost to the IB-G or all wires to the valve severed, the valve will remain

in its last position. Solenoid valves may be desired before the step motor valve on critical applications. The IB-G can power one or two valves. Two bipolar valves may be used and will operate simultaneously and will open and close by the same number of steps. The second valve may be wired into the same terminals as the first valve. See *Appendix C – Wiring Diagram* for details.

Valve force close/open:

If the valve is required to CLOSE during operation, the “CLS” and “REF” terminals should be used. To close the valve and pumpdown the system, short terminals “CLS” and “REF”. On removal of the pumpdown signal the valve will resume position as dictated by the control signal across “S+” and “S-”.

If the valve is required to OPEN during operation, short terminals “OPN” and “REF”. This will cause the valve to open to 100%, once removed the valve will resume normal operation.

To force the valve shut during operation for test purposes, turn switch 8 to the “ON” position. To resume normal operation, turn switch 8 “OFF”. Changing the valve direction set by DIP switch #5 does not affect the pumpdown direction.

Visual Indicators:

The IB-G has three LEDs to visually show the status of the valve and board. See *Figure 3*. The RED LED is a status LED and will be on when that IB-G has power. The YELLOW LED is the Close Valve LED; it will only be on when the valve is fully closed. The GREEN LED is the Valve Open LED and will flash in different sequences depending on valve position. The GREEN LED will flash once for valve positions >0% and including 10%, twice for valve positions >10% and including 20%, etc. The GREEN LED will remain on when the valve is fully open.

Figure 3

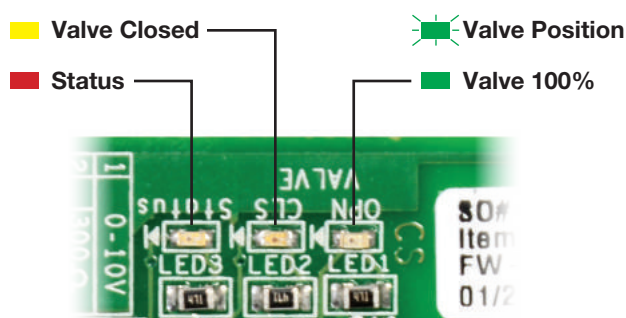

Input Signal Settings (Table 1):

The IB-G can be configured to accept 0-10VDC or 4-20mA analog signal. To configure the input signal, place the jumper on the desired setting. The 4-20mA selection offers several impedance choices based on the external controller. If 4-20mA is selected, ensure that the impedance of the control circuit matches that of the external controller requirements. This will ensure that the maximum valve position, at 20mA, is obtained. Where possible, it is recommended to use a constant current design in the external controller to ensure a proper 4-20mA control signal is supplied to the IB-G.

Valve Selection (Table 2):

This selection must be set to match the step motor valve used on the system. The IB-G was designed for use with Sporlan step motor valves. All other valve manufacturers must be tested and qualified by the end user prior to use to ensure proper valve operation. Reference *Table 4* for valve information.

Table 4

VALVE TYPE	STEP STROKE	MOTOR TYPE
SDR-1x, SDR-2, SDR-2x, SEI-1/2 thru SEI-11	1596	Bipolar
CDS-2,4,7, SER-AA, SER-A, SER-B, SER-C, SER(I)-G, SER(I)-F, SER(I)-J, SER(I)-K	2500	Bipolar
SDR-3, SDR-3x, SEI-30	3193	Bipolar
CDS-9, CDS-16, CDS-17, SDR-4, SEH	6386	Bipolar
SER-B-U, SER-C-U, SER-D-U, SER-E-U	1596	Unipolar
ESX, SEV, CEV	500	Unipolar

DIP Switch Settings (Table 3):

The IB-G has a DIP switch table that accommodates systems that used the legacy Sporlan IB series control boards. Configure the IB-G with the power off. If switches are moved during normal operation, the IB-G will re-initialize the valve and the new settings will take effect.

Bipolar/Unipolar – This selection must be set to match the step motor valve used on the system. The IB-G supports Sporlan SER, CDS and SEH series bipolar valves and SER, ESX and SEV series unipolar valves. Ensure that the valve max steps is set accordingly; see *Table 2*.

STD Direction/REV Direction – This selection allows the valve to operate in reverse direction. STD direction closes the valve based on increasing control signal. To reverse the valve direction, turn the DIP switch #5 to “ON”. This selection does not affect the force close direction when the “CLS” and “REF”, “OPN” and “REF” or forced close DIP switch #8 is turned on.

STD Response/Quick – This selection speeds up valve response to changes in the control signal. Generally, DIP switch #6 is turned ‘ON’ when used in expansion valve applications.

200pps/400pps – This selection allows bipolar valves to be operated either at 200pps (pulses per second) or 400pps. DIP switch #7 can be placed in the ‘ON’ position to enable 400pps. Generally the faster step rate is used on larger chillers or where a faster valve open/close time is desired. Note: the faster step rate is not offered on unipolar valves.

STD Operation/Close Valve – This selection allows for the valve to be manually closed via DIP switch #8. By turning this ‘ON’, the valve will move to the 0%, closed position. This feature can be used for service and troubleshooting. The switch must be turned to ‘OFF’ to resume normal operation.

4. Troubleshooting

When properly configured and installed, the IB-G requires no maintenance. There may be instances; however; where system troubleshooting is required. If a problem arises, it is recommended to **revisit the wiring first** to ensure proper wire location on the terminals and that all wires are tightened accordingly.

Test the valve:

The resistance of the motor winding may be tested without opening the system.

1. Remove power from the external controller and IB-G.
2. Remove valve leads from the IB-G.
3. Measure the resistance between black and white leads of the valve.
 - For the SEI, SDR-4, CDS-9 and CDS-17 valves, the resistance should be $75\Omega \pm 10\%$ at 71°F (21.7°C).
 - For the SER-AA thru SER-D, SERI, CDS-4 and CDS-7 valves, the resistance should be $100\Omega \pm 10\%$ at 71°F (21.7°C).
4. Measure the resistance between the green and red leads. This value should be within $\pm 5\%$ of the resistance between the black and white leads recorded in step 3.
5. Measure the resistance from any lead to the valve body. Resistance should be infinite (open).

PROBLEM	CHECK
IB-G DOES NOT POWER ON	See Figure 3. The RED LED should be on if the IB-G has supply voltage. If not, check for proper supply voltage across terminals 24V+ and 24-. The transformer must be an isolated secondary type.
IB-G CONTINUOUSLY STARTS UP THEN RESETS	Check for reverse polarity across terminals 24V+ and 24V-.
	If multiple IB-Gs are used on one power supply, ensure that all the polarities are correct across the boards.
	Check and ensure ground potentials are the same for the power supplies for both the IB-G and external controller.
VALVE DOES NOT MOVE WITH CONTROL SIGNAL	Ensure RED status LED is on to indicate IB-G is powered.
	If GREEN LED is solid:
	Check to ensure terminals 'OPN' and 'REF' are not shorted.
	If GREEN LED is blinking:
	Check valve wiring to ensure proper location on the IB-G.
	Measure control signal across terminals S+ and S- and ensure it matches the IB-G position established by the 'OPN' LED. For example if the control signal measures 5VDC, ensure the GREEN LED is blinking 4-5 times to denote approximately 50%. See Figure 3 for LED location.
	Check to ensure DIP switch #4 is set correctly.
	Check valve for short or open. (see 'Test the Valve' instructions in Troubleshooting section)
	If YELLOW LED is solid:
	Check to ensure terminals 'CLS' and 'REF' are not shorted.
	Check to ensure DIP switch #8 is set to OFF.
	Note: A short across terminals 'OPN' and 'REF' will position the valve at 100%.
	Note: DIP switch #8 can be placed in 'ON' position to manually position the valve to 0%.
VALVE DOES NOT OPEN TO 100%	If GREEN LED is solid: This denotes that the IB-G has electronically positioned the valve at 100%.
	Check to ensure valve stroke is set correctly based on DIP switches 1-3; see Table 2.
	Check to ensure DIP switch #4 is set correctly.
	Check valve for short or open. (see 'Test the Valve' instructions in the Troubleshooting section)
	If GREEN LED is off or blinking:
	Check signal across terminals S+ and S-. The signal should be 10VDC or 20mA depending on jumper selection found in Table 1. If using 4-20mA control signal, ensure proper selection of impedance to match requirement of external controller.
	Check to ensure DIP switch #5 is set correctly.
	Check to ensure DIP switch #8 is set to OFF.
	Check to ensure there is not a short across terminals 'CLS' and 'REF'.
	Note: A short across terminals 'OPN' and 'REF' will position the valve at 100%.
VALVE DOES NOT CLOSE TO 0%	If YELLOW LED is solid: This denotes that the IB-G has electronically positioned the valve at 0%.
	Check to ensure valve stroke is set correctly based on DIP switches 1-3; see Table 2.
	Check to ensure DIP switch #4 is set correctly.
	Check valve for short or open. (see 'Test the Valve' instructions in the Troubleshooting section)
	If YELLOW LED is off:
	Check signal across terminals S+ and S-. The signal should be 0VDC or 4mA depending on jumper selection found in Table 1.
	Check to ensure there is not a short across terminals 'OPN' and 'REF'.
	Check to ensure DIP switch #5 is set correctly.
Note: DIP switch #8 can be placed in 'ON' position to manually position the valve to 0%.	
VALVE MOVES THE WRONG WAY	Check valve wiring to ensure lead wires match color code on the IB-G terminals.
	Check DIP switch #5; this reverses direction of the valve.
GREEN LED IS BLINKING	This denotes normal operation. The blinking indicates how far the valve is open. For example 2 blinks is approximately 20% open.
ALL LEDS ARE BLINKING	This denotes that the DIP switches are positioned in an invalid configuration.
	Check DIP switches, Table 3, to ensure IB-G is set up correctly.

APPENDIX A - Ordering Information

ITEM DESCRIPTION

IB-G INTERFACE BOARD
POWER SUPPLY (100-240 VAC/24VDC)

ITEM NUMBER

953580
953444

APPENDIX B - Technical Specifications

ELECTRICAL

Supply Voltage

22-28VAC 50/60Hz or 22-28VDC; Class II input

Digital Inputs

Interface to dry contact or open collector

Indicators

Red LED - Power

Yellow LED - Valve Closed

Green LED - Valve Open

Analog Inputs

0-10VDC

4-20mA

MECHANICAL

Operating Temperature

-22°F to 158°F (-30°C to 70°C)

Storage Temperature

-30°F to 170°F (-34°C to 77°C)

Humidity

10-95%RH (Non-Condensing)

Wiring

Screw Terminal

Mounting

SNAP Track

Mounting Holes

COMPLIANCE

CE

RoHS

APPENDIX C - Wiring Diagram

BIPOLAR VALVE

Wiring Bipolar Valve to IB-G

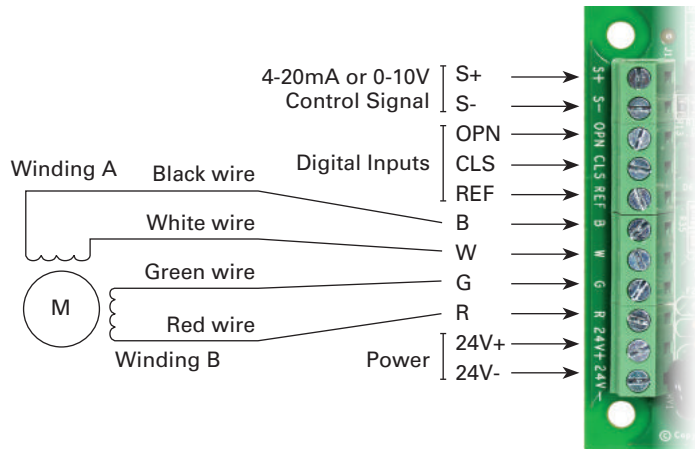

Wiring Power to IB-G (Bipolar valves only)

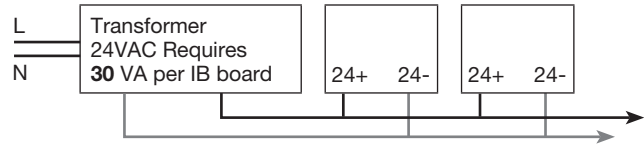

Single Step Motor Valve per IB

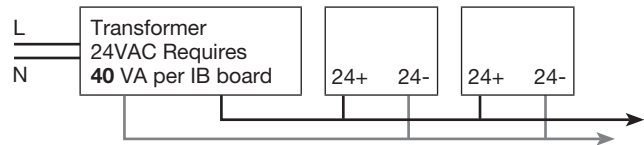

Two Step Motor Valve per IB

UNIPOLAR VALVE

Wiring Unipolar Valve to IB-G

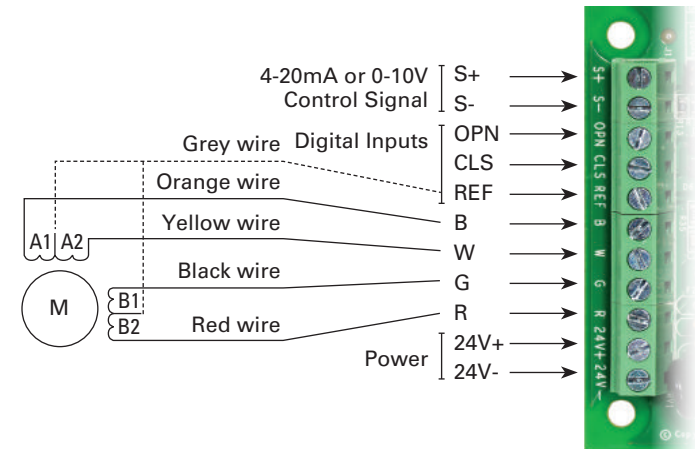

Wiring Power to IB-G (Unipolar valves only)

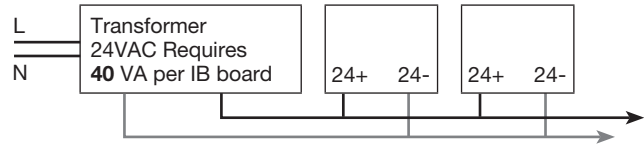

Single Step Motor Valve per IB

