



SPORLAN

Electric Expansion Valves

SER, SERI, SEHI



ENGINEERING YOUR SUCCESS.

FEATURES AND BENEFITS

- Step motor operated for precise control
- High resolution drive assembly
- Solenoid tight seating
- Corrosion resistant materials used throughout
- Field proven reliability
- Low power consumption (less than 4 watts)
- Unique built-in sightglass - indicates valve operation, moisture levels and refrigerant quality (SERI & SEHI only)
- Compatible with HCFC and HFC refrigerants and oils, in addition to subcritical CO₂
- Self lubricating materials used for long life
- High linear force output

The SER, SERI and SEHI are Electronically Operated Step Motor flow control valves, intended for the precise control of liquid refrigerant flow. Synchronized signals to the motor provide discrete angular movement, which translate into precise linear positioning of the valve piston. Valve pistons and ports are uniquely characterized, providing extraordinary flow resolution and performance. The SER, SERI and SEHI valves are easily interfaced with microprocessor based controllers, including Sporlan supplied controllers.

THE VALVES

Sporlan Electric Expansion Valves (EEVs), now rated at full stroke (100% open) with no reserve capacity, are currently available in nominal R-22 capacities from 2.5 to 434 tons (8.2 to 1424 kW), and can control refrigerant flow down to 10% of rated capacity. Therefore, they are applicable on all the same types of systems found in the air conditioning and refrigeration industries as thermostatic expansion valves. Sporlan electric valves are designed for compatibility with all current halocarbon refrigerants (HCFCs and HFCs including R-410A), in addition to subcritical CO₂. System conditions will dictate which product is necessary to control the application. Specific details can be reviewed with your Sporlan Sales Engineer.

⚠ WARNING – USER RESPONSIBILITY

Failure or improper selection or improper use of the products described herein or related items can cause death, personal injury and property damage.

This document and other information from Parker Hannifin Corporation, its subsidiaries and authorized distributors provide product or system options for further investigation by users having technical expertise.

The user, through its own analysis and testing, is solely responsible for making the final selection of the system and components and assuring that all performance, endurance, maintenance, safety and warning requirements of the application are met. The user must analyze all aspects of the application, follow applicable industry standards, and follow the information concerning the product in the current product catalog and in any other materials provided from Parker or its subsidiaries or authorized distributors.

To the extent that Parker or its subsidiaries or authorized distributors provide component or system options based upon data or specifications provided by the user, the user is responsible for determining that such data and specifications are suitable and sufficient for all applications and reasonably foreseeable uses of the components or systems.

FOR USE ON REFRIGERATION and/or AIR CONDITIONING SYSTEMS ONLY

For more information about our products visit us at www.sporlan.com.

Bulletin 100-20, April 2018 supersedes Bulletin 100-20, January 2012, and all prior publications.

ELECTRIC VALVE BASICS

In current designs, the electronics controlling the valve are separate from the valve itself. The correct term to describe the valves is therefore *electronically controlled electric valves*. For convenience, the balance of this discussion will use the term *electric valve*. Since electric valves are assigned their function in the system by the software in the controller, an electric valve can be used anywhere in the system; as an expansion valve, discharge gas bypass valve, evaporator control valve, heat reclaim valve, head pressure control valve or crankcase pressure control valve. Certain design characteristics may indicate or restrict application to certain system conditions, but the fundamental operation of a Sporlan electric valve is consistent. The balance of this bulletin will focus on application as an Electric Expansion Valve (EEV).

TYPES OF ELECTRONICALLY CONTROLLED VALVES

Four basic types of electric valves have historically been offered to the marketplace; solenoid or pulse, analog, heat motor and step motor. Step motor valves, as shown in Figure 1, are the most sophisticated design. In this type of valve a small motor is used to open or close the valve port. The motor that is used does not rotate continuously, but instead, rotates a fraction of a revolution for each signal sent by the controller. These discrete “steps” give the motor its name. The number of step signals sent by the controller is “remembered”, and the controller can return the valve to any previous position at any time. This repeatability is almost absolute and extremely fine control can be obtained. The digital circuitry used by step motor controllers can respond quickly and accurately. Sporlan step motors can be run at 200 steps/second using a voltage driver (L/R). Other step rates should be fully qualified to ensure valve performance and no loss of steps. Sporlan Electric Expansion Valves are designed for 2500 or 6386 steps, so extraordinary resolution and control of flow is possible.

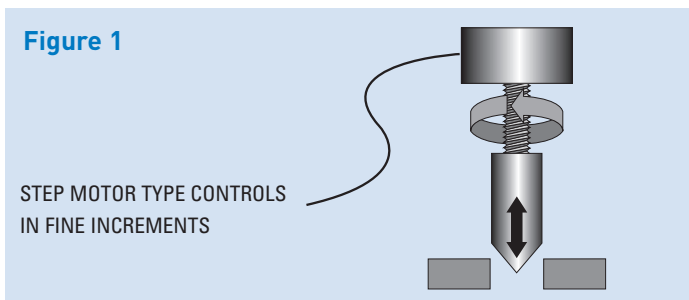

STEP MOTORS

Step motors have existed for many years, but were traditionally limited to very specialized, and often expensive, applications. When the personal computer industry expanded and automobiles became more electronically controlled, the need

for small, reliable and inexpensive step motors increased dramatically. Step motors permitted the repeatable precision movement needed for high speed printers and computerized engine management. In the 1980s Sporlan began research into step motor technology, and production step motor valves were offered in the early 1990s.

STEP MOTOR THEORY

Unlike traditional motors that will rotate as long as the proper power is supplied, step motors rotate a known amount of arc and then stop. When power is removed and then reapplied the step motor will rotate another fixed amount (or step) and again stop. This cycle may be repeated indefinitely, within mechanical limits, in either direction. While seemingly complex, this start/stop motion is mechanically simpler than induction or commutated motors. Step motors, like almost all motors, are based on the magnetic principal that opposite poles attract and like poles repel. These poles are called North (N) and South (S).



If the center magnet above is free to rotate, then the orientation shown will always occur. If electromagnets are used, then a pivoted magnet or rotor can be made to align with the magnetic fields created when the electromagnets are energized.

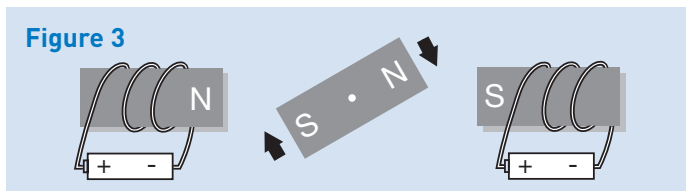

If power is left on, the magnetic poles will align and no further motion will take place.



If multiple groups of electromagnets are placed around a freely rotating permanent magnet rotor, and each is energized in series, then the rotor will step to each alignment position and a step motor is created.

Figure 5

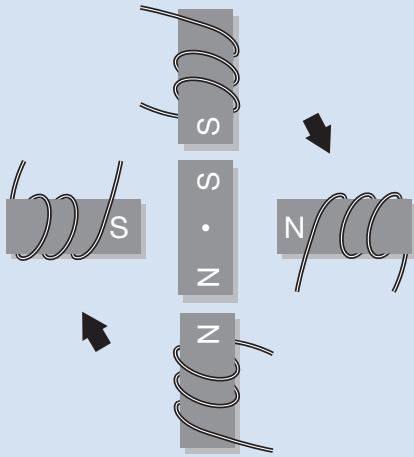

The above is a simple example. In reality, step motors may have 24 to 100 virtual electromagnets arranged around the rotor. Simple arithmetic shows these motors to have 15° to 3.6° step angles, or increments of rotation.

There are two general types of step motors: unipolar and bipolar. In a unipolar style, current flows in only one direction. In a typical example, one lead is always at +12 volts DC, and each of the other four leads is, in turn, connected to a ground. Drive circuitry is simpler, but torque and efficiency are lower than bipolar designs. However, unipolar motors have found acceptance in small capacity systems, within certain application limits. A bipolar motor, such as used in Sporlan electric valves, is powered by signals that change polarity. For the first step the black lead may be negative while the white is positive, but for the second step the black becomes positive while the white becomes negative. This push/pull increases torque and efficiency for motor size and power input, by utilizing the entire motor winding at all times. Bipolar is the predominant style of choice in the industry for larger step motor valves.

DIGITAL LINEAR ACTUATORS - DLAs

Small increments of rotation may be useful in print head drives or for signaling purposes, but often a linear movement is more desirable. In the case of electric refrigerant control valves, not only is linear motion needed, but significant linear force is also needed to close a port against high pressure. The solution to both these needs is a Digital Linear Actuator, or DLA (Figure 6). DLAs are used to convert rotation to a push/pull, often with a large increase in output force. The force increase is derived from a simple gear train, and may account for a fivefold increase in mechanical advantage. This torque increase is used to turn a drive screw or threaded shaft. A drive nut, or coupling,

Figure 6

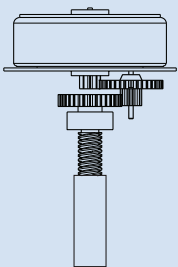

is threaded onto the shaft but prevented from turning by keyways, or specially shaped guides. Since the drive nut cannot turn, it must move forward or backward, depending on the rotation of the threaded shaft.

RESOLUTION

Resolution is defined as the ability of the valve to meet flow requirements accurately. In a pulse type valve only two stages of resolution are possible, fully open or fully closed. Theoretically, if a valve needs to meet a 50% load then it may remain closed for half the time and be fully open for half the time. The control of temperature and superheat will fluctuate as the valve alternately saturate and starves the evaporator. If the swings are 6°, we say the resolution is $\pm 3^\circ$. An Analog Electric Valve or TEV has better resolution because it opens and closes smoothly. In both valves, however, there is hysteresis.

Hysteresis is the internal friction of any system. In a TEV it takes more force or pressure to deform the diaphragm in the opening direction than in the closing direction. This hysteresis has an effect on the resolution of the TEV, and limits its ability to precisely meter refrigerant over widely changing head pressure and evaporator load conditions. Balanced ported TEVs, like Sporlan BF and O series valves, have a much greater ability to follow load than conventional TEVs, but still not to the extent that EEVs can.

The resolution of an Electric Expansion Valve (EEV) is governed by the stroke and number of steps in that stroke. Sporlan offers nine standard Electric Expansion Valves to cover the full nominal capacity range from 2.5 to 434 tons (8.2 to 1424 kW) using R-22. All valves currently offer 2500 steps of stroke, except for the two largest valves, which have 6386 steps. The piston or pin moves the same linear distance for each step. For Sporlan EEVs, this distance ranges from 0.00008" to 0.00012" (0.002mm to 0.003mm). This extremely small change in the distance the pin moves away from the seat is reflected in a minute amount of refrigerant flow increase or decrease. Pulse type valves, with only open and shut capabilities, have inferior resolution. A simple analogy is comparing an on/off light switch which has only two steps of resolution and a dimmer switch which may have thousands. You may be exposed to the same amount of light by setting the dimmer to 50%, or by flickering the light on and off rapidly, but the impact to the room is very different.

CONTROL HARDWARE

Actual control hardware for the valves may take a variety of forms. The most complex and expensive utilizes discrete or individual transistors for each switching function. This design requires the use of eight transistors, labeled Q1 through Q8, connected as shown in the schematic Figure 7.

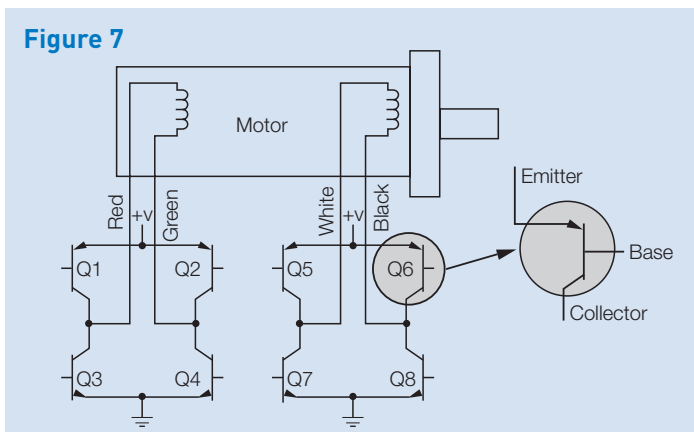

Transistors are simply solid state switches. Solid state means they are fabricated from a solid chip of silicon and have no moving parts. They act as switches or relays by using a small electrical signal to turn a large signal off and on. In the symbol above, the small signal enters the “base” lead and allows flow from emitter to collector. The microprocessor, or small computer, used in the controller has the ability to sequence signals to the “base” of each transistor. This sequence of signals turn the transistors on and off in pairs, to step the valve open or shut. Transistors are available as bipolar (not to be confused with motors of the same name) which control current, and MOSFET (Metal Oxide Semiconductor Field Effect Transistor) which control voltage. In each type there are also transistors that are used to turn off the supply voltage or the ground. Full exploration of these differences is beyond the scope of this bulletin, but drive circuitry using each of these types have been used successfully.

The drive sequence for Sporlan valves is shown in Table 1 below.

Table 1

BIPOLAR DRIVE SEQUENCE				
STEP	BLACK	WHITE	RED	GREEN
1	12 volts	0 volts	12 volts	0 volts
2	0 volts	12 volts	12 volts	0 volts
3	0 volts	12 volts	0 volts	12 volts
4	12 volts	0 volts	0 volts	12 volts
1	12 volts	0 volts	12 volts	0 volts

As each phase is energized in sequence, the shaft of the motor will move one step in the direction indicated. The sequence repeats as many times as is needed to achieve the position calculated by the external electronic controller. Reversing the sequence changes the direction of the motor shaft. Proper sequencing allows the valve to open and close without loss of steps. While properly configured drives may be able to reverse direction without pausing, it is recommended to pause 25 ms prior to reversing direction to prevent loss of steps.

Sporlan Digital Linear Actuators will maintain position when power is removed. This “brake” effect allows controllers to be simpler and use less energy. Sporlan suggests that all

voltage be removed from the motor when not actively stepping to minimize heat and power consumption. Over 130 pounds of force (578 newtons) are needed to cause the motor to turn when not powered. This is not possible in any proper application of the valve.

SOFTWARE

The valves, with their motors and wiring, and the controllers, with their transistors and microprocessors, are grouped together as “Hardware”. To make the hardware perform a function, a set of instructions must be given to the microprocessor. This set of instructions is called “Software” and certain “routines” must be incorporated to make valve control possible.

Most step motor valves are designed without internal intelligence or feedback, that is, they move only in response to controller signals. The valves maintain their position when no signals are received and valve position is stored in controller memory. When the valve is given a signal to change position the controller keeps track of the change, however, the controller does not directly “know” whether the valve has changed position. To make this form of control effective, two control routines must be implemented: initialization and feedback loops.

INITIALIZATION & REINITIALIZATION

Initialization occurs when the valves are powered up for the first time, and after a loss of power. When the controller and valve combination are first powered together, the control does not know the valve position. To initialize, the controller sends out a stream of closing steps greater than the total number of steps in the valve stroke. This will assure that the valve is closed. This closed position becomes the “0” (zero) position of the valve used in all subsequent controller calculations.

This series of extra steps is called “overdriving”, and the valves have been designed to accept this. The actual number of overdriving steps required is dependent upon the valve used. The actual number of mechanical travel steps of the valves is larger than the number of flow control steps, to account for design requirements and manufacturing tolerance. To ensure that the valves are completely closed during initialization, valves that have 2500 steps of flow control require 3500 steps of initialization. For the largest valves that have 6386 steps of control, 6500 steps of initialization are specified (reference Table 2).

Table 2

INITIALIZATION	
VALVE TYPE	STEPS
SER-B, -C, -D	3500
SERI-G, -J, -K, -L	3500
SEHI-175, -400	6500

Once the valve is fully closed and the controller knows the “0” valve position, the algorithm may be implemented with the aid of a feedback loop.

When properly controlled, Sporlan valves should not lose steps, and therefore it is not recommended that a full initialization take place every time the valve is closed. It is reasonable to *reinitialize* the valve no more than once per day. This should not exceed 10% of the valve’s steps. If this is exceeded, excessive overdriving can reduce the life of the valve.

FEEDBACK LOOPS

Feedback occurs when the result of a process is sensed and the sensory information is used to modify the process. In simpler terms, when the controller opens the EEV too much, causing overcooling, the temperature sensor “feeds back” that information, and the controller closes the valve (Figure 8). Step motor valves could be designed with internal feedback that would report the actual position of the valve in number of steps open; however, this would be expensive and undesirable in terms of temperature control.

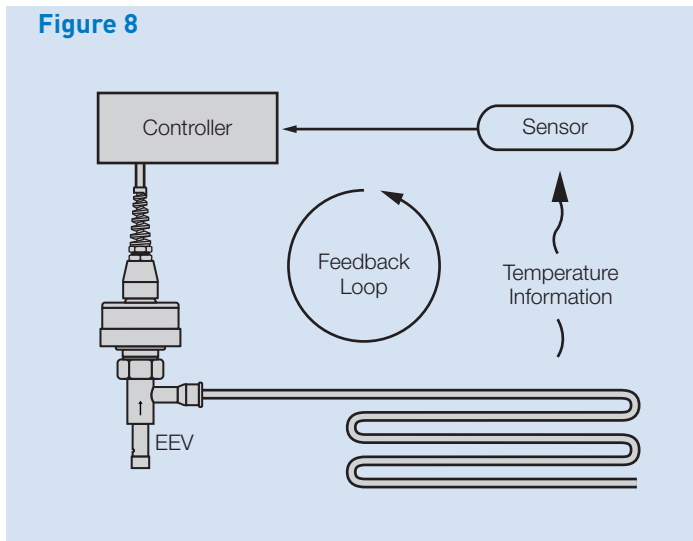

If a control algorithm were written with only references to absolute number of steps open, then changes in head pressure, liquid temperature, etc. would not be taken into account and control would be poor. Instead, sensors are used to ascertain the effect of valve position on temperature and the position is changed to bring the sensed temperature closer to the set point.

VALVE OPERATION

The SER, SERI and SEHI valves modulate by the electronically controlled rotation of a step motor. The step motor drives a gear train and lead screw to position a piston (refer to Figure 9). The piston is used to modulate flow through a port.

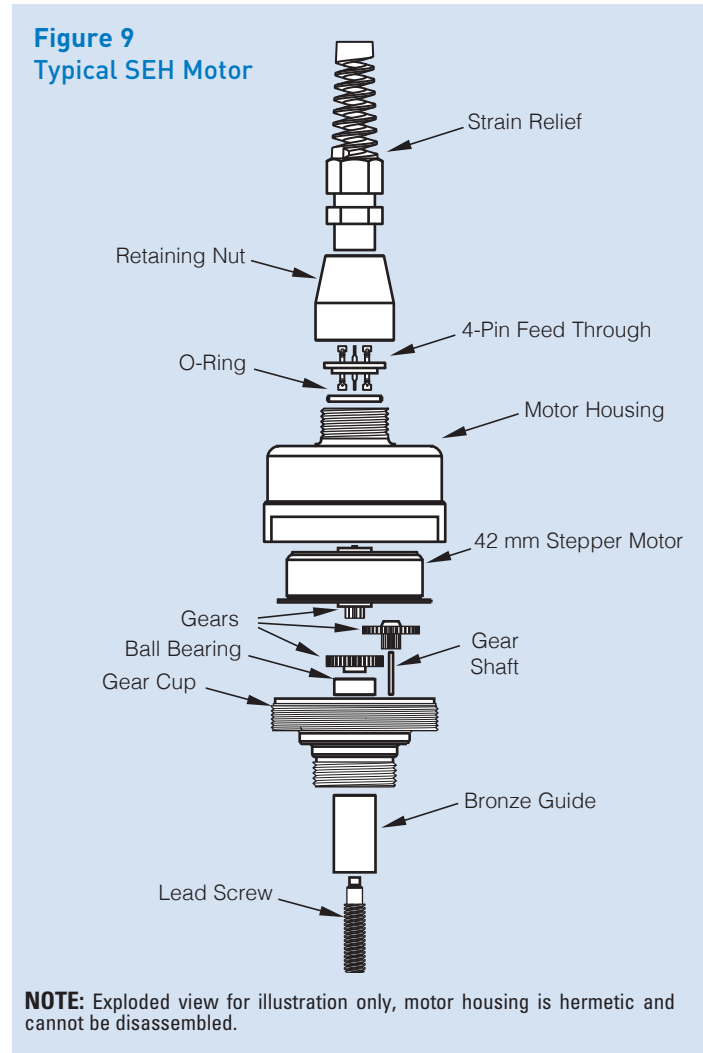

The motor is a two phase type driven in the bipolar mode. Two discrete sets of motor stator windings are powered in sequence to rotate the rotor. Polarity of the drive signal reverses for each step.

The sequencing is accomplished electronically through the bipolar drive circuit shown in Figure 7. The drive transistors, Q1 through Q8, are electronically biased in pairs by the controller as shown in Table 1.

The SER valves have a stroke of 0.23" (5.8mm) and 2500 steps of resolution. Each step yields 0.00009" (0.0023mm) of travel. SERI valves also have 2500 steps, but with 0.297" (7.5mm) of travel, yielding 0.00012" (0.003mm) of travel per step. The SEHI valves have an operating stroke of 0.500" (12.7mm) and 6386 steps of control, therefore each step translates into 0.00008" (0.002mm) of travel. When used with a Sporlan controller, the valves provide unsurpassed accuracy in resolution of flow and repeatability of position.

External parts of the valve are brass, copper and stainless steel, and meet or exceed 2000 hour salt spray tests per ASTM B-117. The SER valves have an innovative uni-body construction that further improves resistance to extreme environmental conditions, as well as an IP-67 rated removable cable that can be installed in any of four possible orientations for ultimate flexibility. The SERI family also comes standard with removable cable, and a detachable motor housing for serviceability. The SEHI valves are also equipped with a removable motor housing, that has a hermetic cable connection to the motor. The leads on all valves can be supplied in a variety of lengths to suit specific customer requirements.

Total power consumption is less than 4 watts when operating at a rate of 200 steps/second with standard L/R type drive circuitry (refer to the Table of Specifications). Faster step rates (up to 400 steps/second) may be obtained with properly configured current limited "chopper" type drives. Additional qualification testing is needed to validate valve operation. Please contact Sporlan for more information.

The SER-B and SER-C are now rated at a safe working pressure of 1015 psig (70 bar). The remainder of the SER and SERI valves are rated 700 psig (48 bar) MRP, while the SEHI-175 and SEHI-400 are rated 620 psig (43 bar) and 500 psig (34 bar), respectively. Operating ambient temperature range is -50°F to 155°F (-45°C to 68°C) but temperatures of up to 250°F (121°C) may be used for dehydration.

APPLICATION

Sporlan is not responsible for system design, for any damage arising from faulty system design, or for misapplication of its products. If these valves are applied in any manner other than as described in this bulletin, the Sporlan warranty is void. Please contact your Sporlan Sales Engineer for assistance with your specific application.

It is the responsibility of the controller manufacturer to provide suitable drive circuitry and power supply. Sporlan will assist where necessary, but accepts no liability for improper control of the valve. Careful consideration should be given to the interaction between the valve controller and system controller (if independent), to ensure proper behavior in all system conditions. Control strategy is a critical factor in determining valve duty cycle and superheat control capability.

It is strongly suggested that power be disabled to the valve when not actively stepping. While properly configured drives may be able to reverse direction without pausing, it is recommended to pause 25 ms prior to reversing direction to prevent loss of steps. Conventional initialization routines, which include overdriving the motor to ascertain the zero step position are acceptable. Contact Sporlan for more information.

SELECTION PROCEDURE

Sporlan Electric Expansion Valves (EEVs) are one part of a system used for refrigerant flow control in air conditioning or refrigeration applications. The other parts of the system are sensors and an electronic controller. The EEV controls the flow of refrigerant entering the direct expansion (DX) evaporator in response to signals sent by the controller. These signals are calculated by the controller from sensor inputs. A set of sensors, either two temperature sensors or a pressure transducer and a temperature sensor, are used to measure superheat. Typical control is based on superheat set point but an additional temperature sensor may be used to measure discharge water or air temperature. This air or water temperature may be controlled directly, as long as superheat remains at a level sufficient to prevent floodback. The ability of the EEV to control the amount of refrigerant in the evaporator to reach discharge set point while preventing floodback makes the EEV the ideal expansion device for most air conditioning, chiller, environmental chamber and refrigeration applications. Some EEV controllers can be programmed to follow unique control algorithms making the EEV especially useful for many diverse applications.

The actual selection of EEV valves should be based on information generally required for any expansion valve. The following procedure should be used when selecting a Sporlan EEV.

1. **Determine refrigerant to be used.** Sporlan electric valves are designed for compatibility with all current halocarbon refrigerants (HCFCs and HFCs including R-410A), in addition to subcritical CO₂.
2. **Determine capacity required for the valve.** This is normally the evaporator capacity at the desired conditions.
3. **Determine pressure drop across valve.** Subtract the evaporating pressure from the condensing pressure. The condensing pressure used in this calculation should be the minimum operating condensing pressure of the system. From this value, subtract all other pressure losses to obtain the net pressure drop across the valve. Be sure to consider all of the following possible sources of pressure drop: (1) friction losses through refrigeration lines including the evaporator and condenser; (2) pressure drop across liquid line accessories such as a solenoid valve and filter-drier; (3) static pressure loss (gain) due to the vertical lift (drop) of the liquid line; and (4) pressure drop across a refrigerant distributor, if used. Refer to Bulletin 20-10 for further information on refrigerant distributors.

4. **Determine the liquid temperature of the refrigerant entering the valve.** The EEV capacity tables in this bulletin are typically based on a liquid temperature of 100°F (38°C). For other liquid temperatures, apply the correction factor shown below the tables for each refrigerant.
5. **Select valve from the capacity tables.** Select a valve based on the design evaporating temperature and the available pressure drop across the valve. Sporlan EEVs are now rated

at full stroke (100% open), with no reserve capacity. Due to superior resolution and flow control capability across the entire operating range, Sporlan EEVs can be applied down to 10% of nominal capacity. Be sure to apply the appropriate liquid temperature correction factor to the valve ratings shown in the tables. Once the desired valve capacity has been located, determine the valve model from the first column of the appropriate table. On multiple evaporator systems, select each valve on the basis of individual evaporator capacity.

SELECTION EXAMPLES:

Refrigerant: R-410A	
Condensing Temperature: 100°F	
Liquid Temperature: 90°F	
Evaporator Temperature: 40°F	
Liquid Line Loss: 7 psi	
ΔP Distributor and Tubes: 35 psi*	
Evaporator Load: 5 tons	
Condensing Pressure (psig):	320
Liquid Line Loss (Estimate):	- 7
Distributor and Tubes:	-35
Evaporator Pressure (psi):	<u>-118</u>
ΔP across EEV:	160
R-410A, 90°F Liquid Correction Factor: 1.08	
SER-B: 2.97 tons x 1.08 = 3.21 tons	
SER-C: 8.05 tons x 1.08 = 8.69 tons	
Select an SER-C from the capacity table.	

Refrigerant: R-134a	
Condensing Temperature: 32°C	
Liquid Temperature: 27°C	
Evaporator Temperature: -10°C	
Liquid Line Loss: 0.5 bar	
ΔP Distributor and Tubes: 1.7 bar*	
Evaporator Load: 900 kW	
Condensing Pressure (bar):	7.2
Liquid Line Loss (Estimate):	- 0.5
Distributor and Tubes:	- 1.7
Evaporator Pressure:	<u>- 1.0</u>
ΔP across EEV:	4.0
R-134a, 27°C Liquid Correction Factor: 1.16	
SEHI-175: 482 kW x 1.16 = 559 kW	
SEHI-400: 1006 kW x 1.16 = 1167 kW	
Select an SEHI-400 from the capacity table.	

*See Sporlan Bulletin 20-10 for pressure drop data as related to percent loading.

ORDERING INSTRUCTIONS / NOMENCLATURE*

Sporlan valves are available in angle and/or straight through offset configurations (reference the Available Connections table for additional details). The SERI and SEHI valves feature a built-in sightglass (not available on the small SER family of valves). The sightglass indicates the moisture level of

the refrigerant, flash gas present upstream of the valve, and provides a visual confirmation of valve piston movement. This unique feature is useful for system refrigerant charging, service and diagnostics.

SER-B, -C, -D

SER	C	3/8"	x	1/2"	ODF	10'	S
Valve Family	Valve Model	Inlet Fitting Size		Outlet Fitting Size	Fitting Type	Cable Length	Stripped and Tinned Cable Ends (Custom Connectors Available)

SERI-G, -J, -K, -L

SERI	J	S	7/8"	x	1-1/8"	ODF	40'	S
Valve Family	Valve Model	Straight Through Offset Configuration (blank if angle)	Inlet Fitting Size		Outlet Fitting Size	Fitting Type	Cable Length	Stripped and Tinned Cable Ends (Custom Connectors Available)

SEHI-175

SEHI	175	1-5/8"	x	2-1/8"	ODF	30'	S	AN
Valve Family	Valve Model	Inlet Fitting Size		Outlet Fitting Size	Fitting Type	Cable Length	Stripped and Tinned Cable Ends (Custom Connectors Available)	Angle Configuration (blank if straight through offset)

SEHI-400

SEHI	400	2-1/8"	x	2-1/8"	ODF	20'	S	AN
Valve Family	Valve Model	Inlet Fitting Size		Outlet Fitting Size	Fitting Type	Cable Length	Stripped and Tinned Cable Ends (Custom Connectors Available)	AN -Angle Configuration ST -Straight Through Configuration

* Refer to Available Connections table for specific configurations, fitting sizes and cable lengths.

SPECIFICATIONS					
VALVE	SER-B,-C	SER-D	SERI-G, -J, -K, -L	SEHI-175	SEHI-400
Motor type	2 phase, bipolar wet motor				
Compatible refrigerant	All common HCFC and HFC refrigerants including R-410A and subcritical R-744				All common HCFC and HFC refrigerants
Compatible oils	All common Mineral, Polyolester and Alkybenzene oils				
Supply voltage (L/R)	12 volt DC, -5%, +10% measured at the valve leads				
Cable type	IP67 Removable Quad-Position	IP67 Removable Quad-Position	Hermetic	Hermetic	Hermetic
Phase resistance	100 ohms +- 10%	100 ohms +-10%	75 ohms +-10%	75 ohms +-10%	75 ohms +-10%
Chopping current*	Evaluate to avoid step loss or damage to the valve*				
Maximum power input (L/R)	2.8 watts	2.8 watts	3.8 watts	3.8 watts	3.8 watts
Recommended step rate	200/second (L/R), up to 400/second (current limited)				
Number of steps	2500	2500	6386	6386	6386
Resolution	.00009" (.0023 mm) / step	.00012" (.003 mm) / step	.00008" (.002 mm) / step	.00008" (.002 mm) / step	.00008" (.002 mm) / step
Stroke	0.23" (5.8 mm)	.297" (7.5 mm)	.500" (12.7mm)	.500" (12.7mm)	.500" (12.7mm)
MOPD	580 psid (40 bar)	500 psid (34 bar)	500 psid (34 bar)	500 psid (34 bar)	300 psid (21 bar)
MRP	1015 psig (70 bar)	700 psig (48 bar)	700 psig (48 bar)	620 psig (43 bar)	500 psig (34 bar)
Max. internal leakage	100 cc/min @ 100 psid (6.9 bar), dry air				
Max. external leakage	.10 oz./yr at 300 psig (2.8 gram/yr @ 20 bar)				
Operating temp range	-50°F to 155°F (-45°C to 68°C)				
Materials of construction	Brass, copper, synthetic seals, stainless steel				

* Contact Sporlan Application Engineering for qualification testing details.

SER-B, -C

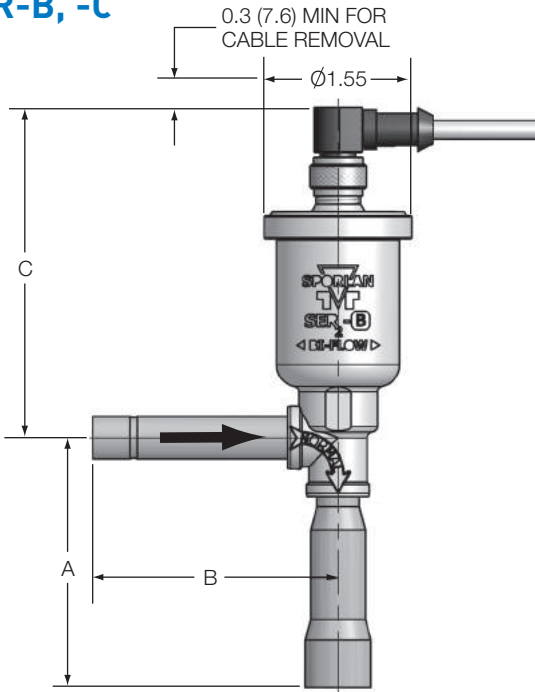

SER-DS

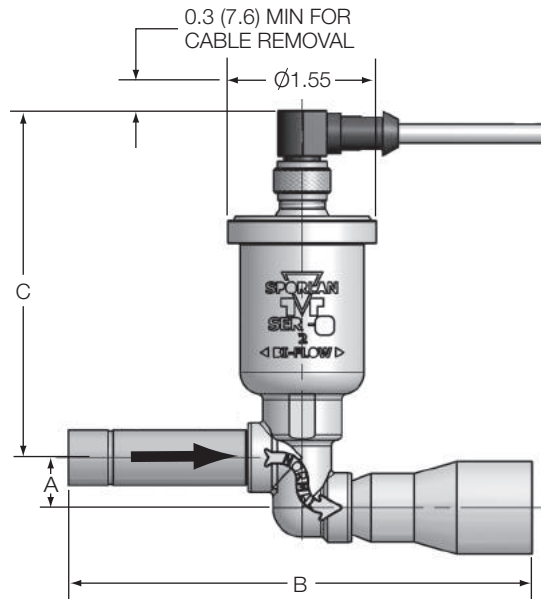

SERI-G, -J, -K, -L
(Angle)

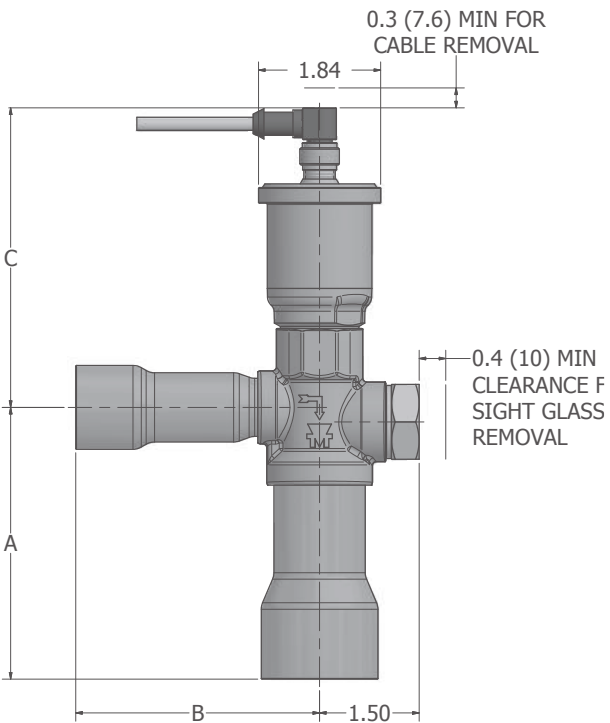

SERI-GS, -JS, -KS, -LS
(Straight Through Offset)

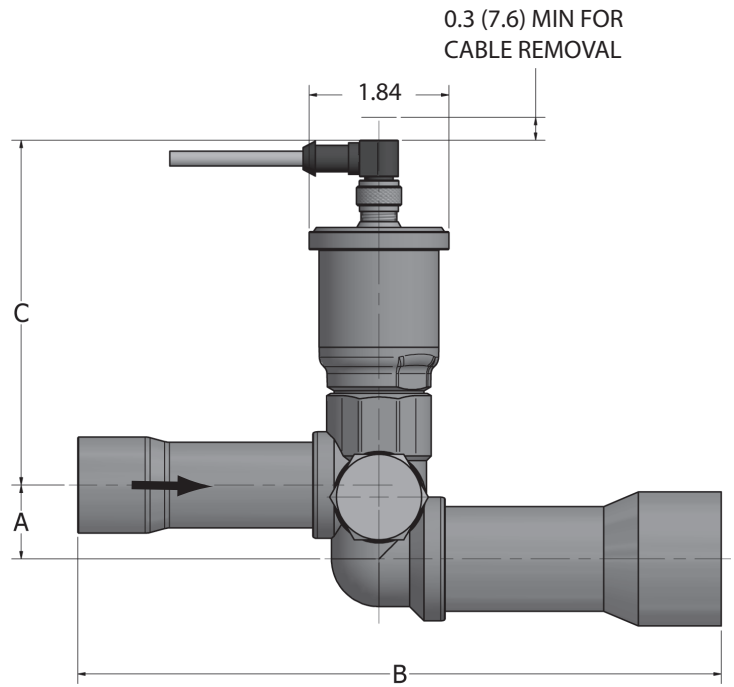

SEHI-175

(Angle)

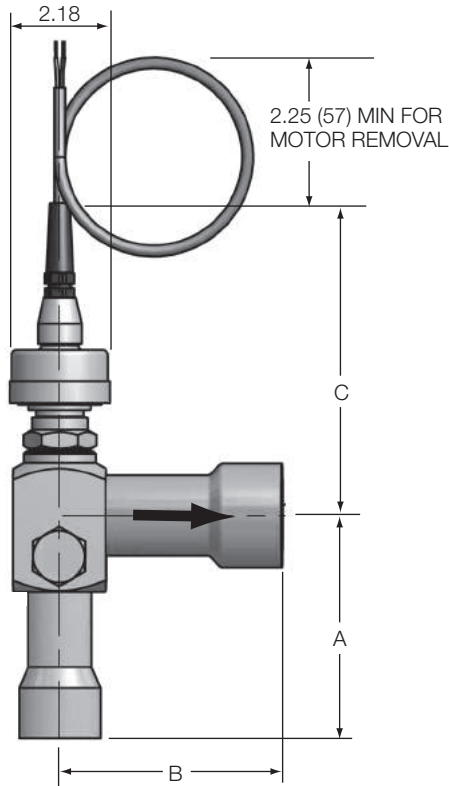

SEHI-175

(Straight Through Offset)

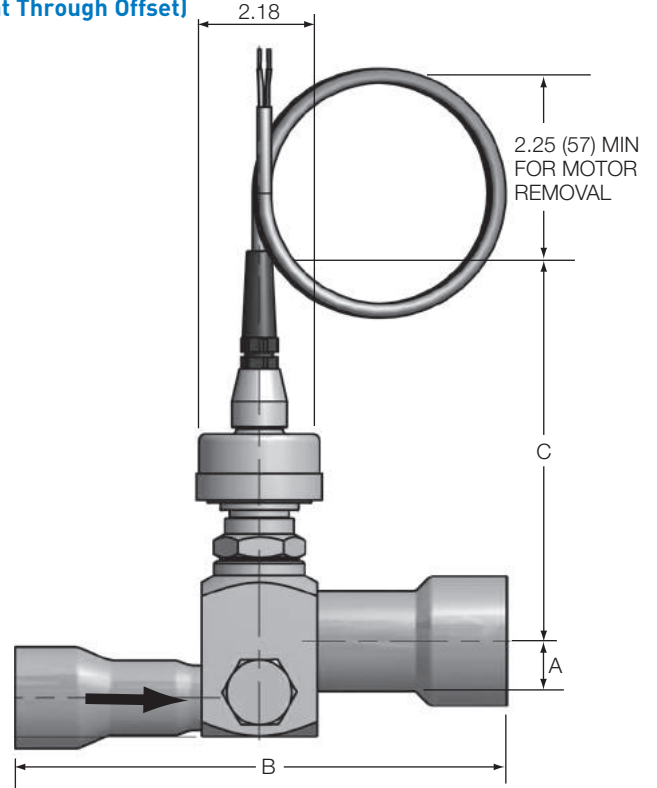

SEHI-400

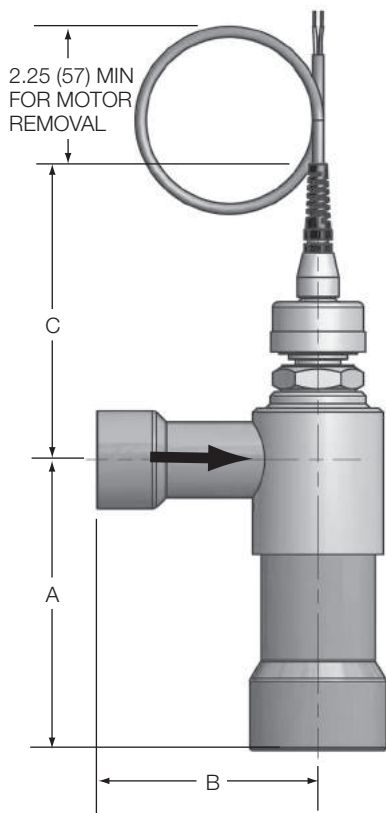

REFERENCE DIMENSIONS / Inches (mm) *				
VALVE	CONFIGURATION	A	B	C
SER-B	Angle	2.63 (66.8)	2.56 (65.0)	3.57 (90.7)
SER-C	Angle	2.63 (66.8)	2.56 (65.0)	3.57 (90.7)
SER-DS	Straight Through Offset	0.52 (13.2)	4.83 (122.7)	3.57 (90.7)
SERI-G	Angle	3.65 (92.7)	3.11 (79.0)	3.61 (91.7)
SERI-J		3.86 (98.0)	3.31 (84.1)	3.61 (91.7)
SERI-K		3.92 (99.6)	3.39 (86.1)	4.05 (102.9)
SERI-L		4.00 (101.6)	3.70 (94.0)	4.06 (103.1)
SERI-GS	Straight Through Offset	0.73 (18.5)	6.84 (173.7)	3.59 (91.2)
SERI-JS		0.73 (18.5)	7.09 (180.1)	3.59 (91.2)
SERI-KS		0.97 (24.6)	7.66 (194.6)	4.01 (101.9)
SERI-LS		0.97 (24.6)	7.69 (195.3)	4.01 (101.9)
SEHI-175	Angle	4.98 (126.5)	4.82 (122.4)	6.85 (174.0)
	Straight Through Offset	0.98 (24.9)	8.50 (215.9)	6.85 (174.0)
SEHI-400	Angle	6.28 (159.5)	5.08 (129.0)	6.71 (170.4)

* Dimensions may vary slightly based upon connection sizes selected

AVAILABLE CONNECTIONS						
VALVE TYPE	INLET – Inches (ODF)	OUTLET – Inches (ODF)	CONFIGURATION	CABLE LENGTH		CABLE ENDS
				FEET	METERS	
SER-B*	1/4, 3/8	3/8, 1/2, 5/8	Angle	10 Less Cable	3 Less Cable	S- Stripped and Tinned (Custom Connections Available)
SER-C*	1/4, 3/8	3/8, 1/2, 5/8	Angle			
SER-DS*	3/8, 1/2, 5/8	1/2, 5/8, 7/8, 1-1/8	Straight Through Offset			
SERI-G*	5/8, 7/8	1/2, 5/8, 7/8, 1-1/8, 1-3/8	Angle or Straight Through Offset	10 Less Cable	3 Less Cable	
SERI-J*	7/8, 1-1/8	7/8, 1-1/8, 1-3/8				
SERI-K†	1-1/8	7/8, 1-1/8, 1-3/8, 1-5/8				
SERI-L†	1-1/8, 1-3/8	1-1/8, 1-3/8, 1-5/8				
SEHI-175	1-1/8, 1-3/8, 1-5/8	2-1/8				
SEHI-400	1-5/8, 2-1/8, 2-5/8	1-5/8, 2-1/8, 2-5/8, 3-1/8 ODM	Angle	10, 20, 30, 40	3, 6, 9, 12	

*Suitable for bi-directional applications.
†Bi-sealing, reduced flow in reverse direction.

CAPACITY

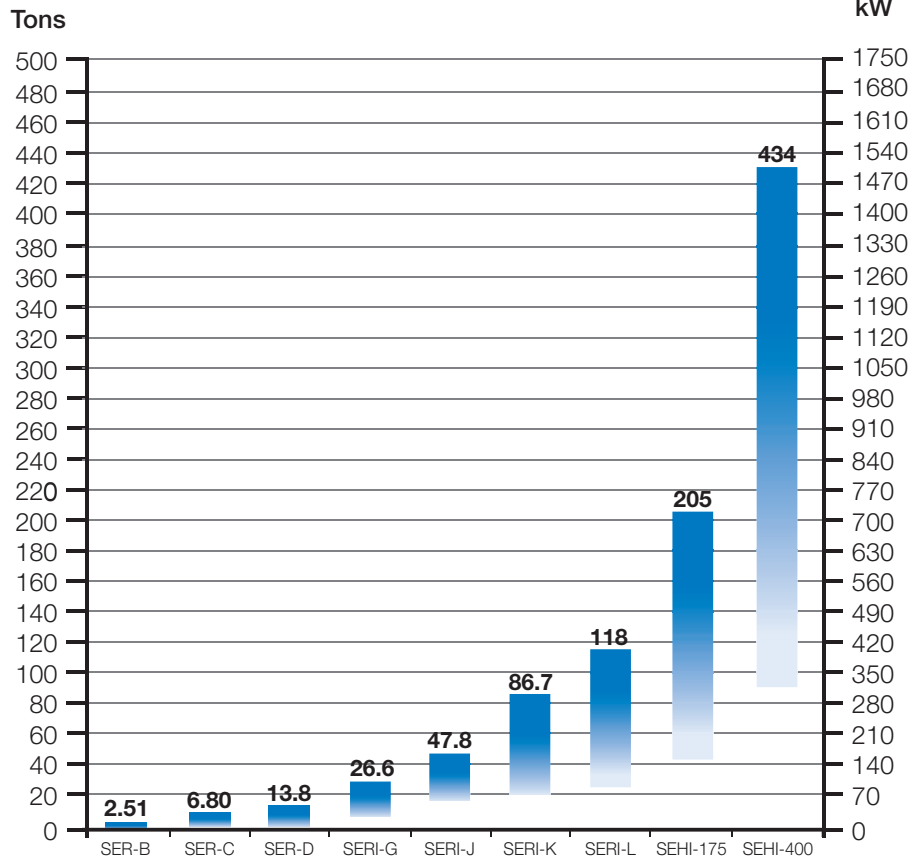
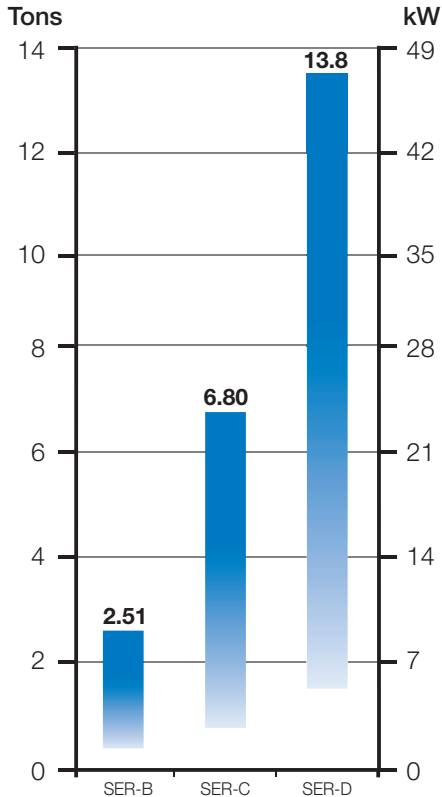

R-22 at 100°F (38°C) liquid, 100 psi (6 bar) pressure drop, 40°F (5°C) evaporator temperature, and full stroke.

Reference Dimensions – Inches (mm)

R-404A Capacities in Tons (at Evaporator Temperature °F)

VALVE TYPE	40°F								20°F								0°F							
	Pressure Drop Across Valve (psid)																							
	75	100	125	150	175	200	225	250	75	100	125	150	175	200	225	250	75	100	125	150	175	200	225	250
SER-B	1.41	1.62	1.81	1.99	2.15	2.29	2.43	2.57	1.33	1.54	1.72	1.89	2.04	2.18	2.31	2.44	1.26	1.45	1.63	1.78	1.92	2.06	2.18	2.30
SER-C	3.81	4.40	4.92	5.39	5.82	6.22	6.60	6.96	3.62	4.18	4.67	5.12	5.53	5.91	6.27	6.61	3.41	3.94	4.41	4.83	5.22	5.58	5.91	6.23
SER-D	7.75	8.95	10.0	11.0	11.8	12.7	13.4	14.2	7.36	8.50	9.51	10.4	11.2	12.0	12.8	13.4	6.95	8.02	8.97	9.82	10.6	11.3	12.0	12.7
SERI-G	15.2	17.6	19.6	21.5	23.2	24.8	26.4	27.8	14.4	16.7	18.6	20.4	22.0	23.5	25.1	26.4	13.6	15.6	17.5	19.2	20.7	22.2	23.5	24.8
SERI-J	27.4	31.6	35.3	38.7	41.8	44.7	47.4	50.0	25.9	30.0	33.5	36.7	39.6	42.4	44.9	47.4	24.4	28.2	31.5	34.5	37.3	39.9	42.4	44.6
SERI-K	49.6	57.3	64.1	70.2	75.8	81.1	86.0	90.6	47.1	54.4	60.7	66.5	71.9	76.8	81.5	85.9	44.4	51.1	57.1	62.6	67.6	72.4	76.6	80.8
SERI-L	66.0	76.2	85.2	93.4	101	108	114	121	62.7	72.4	81.0	88.7	95.8	102	109	114	59.2	68.3	76.4	83.7	90.4	96.6	102	108
SEHI-175	118	136	152	167	180	193	205	215	112	129	145	158	171	182	193	204	105	121	135	148	160	172	182	192
SEHI-400	237	274	307	336	363	388	411	434	226	260	291	319	345	368	391	412	213	246	275	301	325	348	369	389

VALVE TYPE	-20°F								-40°F							
	Pressure Drop Across Valve (psid)															
	75	100	125	150	175	200	225	250	75	100	125	150	175	200	225	250
SER-B	1.18	1.36	1.52	1.67	1.80	1.93	2.04	2.15	1.10	1.27	1.42	1.55	1.68	1.79	1.90	2.00
SER-C	3.20	3.69	4.13	4.52	4.89	5.22	5.54	5.84	2.97	3.43	3.84	4.21	4.54	4.86	5.15	5.43
SER-D	6.51	7.51	8.40	9.20	9.94	10.6	11.3	11.9	6.05	6.99	7.81	8.56	9.24	9.88	10.5	11.0
SERI-G	12.7	14.6	16.4	17.9	19.4	20.7	21.9	23.1	11.6	13.6	15.2	16.6	17.9	19.2	20.4	21.4
SERI-J	22.8	26.4	29.4	32.2	34.8	37.2	39.5	41.6	21.1	24.4	27.3	29.9	32.4	34.5	36.6	38.6
SERI-K	41.3	47.6	53.4	58.4	63.1	67.5	71.6	75.5	38.4	44.2	49.5	54.2	58.5	62.6	66.4	69.9
SERI-L	55.4	64.0	71.5	78.4	84.6	90.5	96.0	101	51.5	59.5	66.5	72.9	78.7	84.1	89.3	94.1
SEHI-175	98.1	113	127	139	149	160	169	179	90.9	105	117	128	139	148	158	166
SEHI-400	199	230	257	282	305	326	345	364	185	214	239	262	283	303	321	338

R-404A Capacities in kW (at Evaporator Temperature °C)

VALVE TYPE	5°C								-10°C								-20°C							
	Pressure Drop Across Valve (bar)																							
	4	6	8	10	12	14	16	18	4	6	8	10	12	14	16	18	4	6	8	10	12	14	16	18
SER-B	4.36	5.34	6.16	6.89	7.55	8.15	8.72	9.24	4.06	4.97	5.74	6.42	7.03	7.60	8.12	8.62	3.85	4.71	5.44	6.08	6.66	7.20	7.69	8.16
SER-C	11.8	14.5	16.7	18.7	20.5	22.1	23.6	25.1	11.0	13.5	15.6	17.4	19.1	20.6	22.0	23.4	10.4	12.8	14.8	16.5	18.1	19.5	20.9	22.1
SER-D	24.0	29.4	34.0	38.0	41.6	45.0	48.1	51.0	22.4	27.4	31.7	35.4	38.8	41.9	44.8	47.5	21.2	26.0	30.0	33.6	36.8	39.7	42.4	45.0
SERI-G	47.1	57.5	66.4	74.4	81.4	87.9	94.0	99.6	43.6	53.4	61.6	69.1	75.6	81.6	87.3	92.6	41.2	50.5	58.4	65.2	71.4	77.1	82.5	87.5
SERI-J	84.5	104	120	134	146	158	169	179	78.5	96.2	111	124	136	147	156	167	74.2	90.8	105	117	128	139	148	156
SERI-K	153	188	216	242	265	287	307	325	142	174	201	225	247	266	285	302	134	165	191	213	233	252	269	285
SERI-L	205	251	289	324	355	383	409	434	191	234	270	302	330	357	382	405	181	221	256	286	313	338	361	383
SEHI-175	364	446	515	575	631	681	728	772	338	414	478	534	586	633	676	718	319	391	452	505	553	598	639	678
SEHI-400	736	902	1041	1164	1275	1378	1473	1562	686	841	971	1085	1189	1284	1373	1456	650	796	919	1028	1126	1216	1300	1379

VALVE TYPE	-30°C								-40°C							
	Pressure Drop Across Valve (bar)															
	4	6	8	10	12	14	16	18	4	6	8	10	12	14	16	18
SER-B	3.62	4.44	5.12	5.73	6.28	6.78	7.25	7.69	3.39	4.16	4.80	5.37	5.88	6.35	6.79	7.20
SER-C	9.83	12.0	13.9	15.5	17.0	18.4	19.7	20.8	9.20	11.3	13.0	14.5	15.9	17.2	18.4	19.5
SER-D	20.0	24.5	28.3	31.6	34.6	37.4	40.0	42.4	18.7	22.9	26.5	29.6	32.4	35.0	37.4	39.7
SERI-G	38.7	47.4	54.8	61.2	67.1	72.4	77.4	82.1	36.1	44.4	51.1	57.1	62.6	67.6	72.4	76.7
SERI-J	69.6	85.3	98.5	110	121	131	139	148	65.1	79.6	91.9	103	113	122	131	138
SERI-K	126	155	179	200	219	236	253	268	118	144	167	186	204	221	236	251
SERI-L	170	208	241	269	295	318	340	361	159	195	225	252	276	298	319	338
SEHI-175	300	367	425	474	520	561	600	636	280	342	396	442	485	524	560	594
SEHI-400	612	750	866	968	1061	1146	1225	1299	573	702	811	907	993	1073	1147	1216

Liquid Temperature Correction Factors

°F	0	10	20	30	40	50	60	70	80	90	100	110	120	130	140
°C	-18	-12	-7	-1	4	10	16	21	27	32	38	43	49	54	60
R-404A	2.04	1.94	1.84	1.74	1.64	1.54	1.43	1.33	1.22	1.11	1.00	0.89	0.77	0.65	0.53

R-507A Capacities in Tons (at Evaporator Temperature °F)

VALVE TYPE	40°F									20°F									0°F					
	Pressure Drop Across Valve (psid)																							
	75	100	125	150	175	200	225	250	75	100	125	150	175	200	225	250	75	100	125	150	175	200	225	250
SER-B	1.36	1.57	1.76	1.93	2.08	2.22	2.36	2.49	1.29	1.49	1.67	1.83	1.97	2.11	2.24	2.36	1.22	1.41	1.57	1.72	1.86	1.99	2.11	2.22
SER-C	3.69	4.26	4.77	5.22	5.64	6.03	6.40	6.74	3.50	4.05	4.52	4.96	5.35	5.72	6.07	6.40	3.30	3.81	4.26	4.67	5.04	5.39	5.72	6.03
SER-D	7.51	8.67	9.70	10.6	11.5	12.3	13.0	13.7	7.13	8.23	9.20	10.1	10.9	11.6	12.3	13.0	6.71	7.75	8.67	9.50	10.3	11.0	11.6	12.3
SERI-G	14.9	17.2	19.2	21.1	22.8	24.4	25.8	27.2	14.1	16.4	18.2	20.0	21.6	23.1	24.5	25.8	13.3	15.3	17.2	18.8	20.4	21.6	23.1	24.4
SERI-J	26.8	31.1	34.6	37.9	41.1	43.8	46.4	49.1	25.4	29.3	32.8	35.9	38.8	41.5	44.0	46.4	23.9	27.6	30.9	33.8	36.5	39.1	41.4	43.6
SERI-K	48.6	56.1	62.8	68.7	74.4	79.4	84.2	88.8	46.0	53.2	59.5	65.1	70.4	75.2	79.8	84.1	43.4	50.1	56.0	61.3	66.2	70.8	75.1	79.2
SERI-L	64.0	73.9	82.6	90.5	97.7	104	111	117	60.7	70.1	78.4	85.8	92.7	99.1	105	111	57.2	66.0	73.8	80.9	87.4	93.4	99.0	104
SEHI-175	115	133	149	164	176	188	200	211	109	126	141	154	167	179	189	200	103	119	133	146	158	168	179	188
SEHI-400	230	266	297	325	352	376	399	420	218	252	282	309	334	357	378	399	206	238	266	291	314	336	356	376

VALVE TYPE	-20°F									-40°F								
	Pressure Drop Across Valve (psid)																	
	75	100	125	150	175	200	225	250	75	100	125	150	175	200	225	250		
SER-B	1.14	1.31	1.47	1.61	1.74	1.86	1.97	2.08	1.06	1.22	1.36	1.49	1.61	1.73	1.83	1.93		
SER-C	3.09	3.56	3.98	4.36	4.71	5.04	5.35	5.63	2.86	3.31	3.70	4.05	4.38	4.68	4.96	5.23		
SER-D	6.28	7.25	8.10	8.88	9.59	10.3	10.9	11.5	5.83	6.73	7.52	8.24	8.90	9.51	10.1	10.6		
SERI-G	12.4	14.4	16.1	17.6	19.1	20.4	21.5	22.7	11.6	13.4	14.9	16.4	17.6	18.9	20.0	21.1		
SERI-J	22.4	25.8	28.9	31.6	34.2	36.6	38.8	40.9	20.8	24.0	26.9	29.4	31.8	34.0	36.0	38.0		
SERI-K	40.6	46.9	52.4	57.4	62.0	66.4	70.4	74.1	37.6	43.6	48.7	53.4	57.6	61.6	65.3	68.9		
SERI-L	53.5	61.7	69.0	75.6	81.7	87.3	92.6	97.6	49.6	57.3	64.1	70.2	75.8	81.0	85.9	90.6		
SEHI-175	96.4	111	125	136	147	158	167	176	89.6	103	116	127	136	146	155	164		
SEHI-400	192	222	248	272	294	314	333	351	179	206	230	252	273	292	309	326		

R-507A Capacities in kW (at Evaporator Temperature °C)

VALVE TYPE	5°C									-10°C									-20°C					
	Pressure Drop Across Valve (bar)																							
	4	6	8	10	12	14	16	18	4	6	8	10	12	14	16	18	4	6	8	10	12	14	16	18
SER-B	4.22	5.17	5.97	6.68	7.31	7.90	8.44	8.96	3.93	4.81	5.56	6.21	6.81	7.35	7.86	8.33	3.72	4.55	5.26	5.88	6.44	6.96	7.44	7.89
SER-C	11.4	14.0	16.2	18.1	19.8	21.4	22.9	24.3	10.7	13.0	15.1	16.8	18.5	19.9	21.3	22.6	10.1	12.3	14.3	15.9	17.5	18.9	20.2	21.4
SER-D	23.3	28.5	32.9	36.8	40.3	43.6	46.6	49.4	21.7	26.5	30.6	34.3	37.5	40.5	43.3	46.0	20.5	25.1	29.0	32.4	35.5	38.4	41.0	43.5
SERI-G	46.0	56.4	65.1	72.8	79.6	86.1	92.1	97.6	42.7	52.4	60.4	67.6	74.0	80.0	85.5	90.7	40.4	49.5	57.2	63.9	70.0	75.6	80.8	85.8
SERI-J	82.8	101	117	131	144	155	166	176	76.9	94.2	109	122	133	144	154	164	72.7	89.1	103	115	126	136	145	154
SERI-K	151	184	212	236	260	281	300	319	139	171	196	220	241	261	279	296	132	162	186	209	228	247	264	280
SERI-L	198	243	280	314	344	371	397	421	185	226	261	292	320	345	369	392	175	214	247	276	302	327	349	370
SEHI-175	356	436	505	564	618	667	713	756	331	406	468	524	573	619	662	702	313	384	442	495	542	586	626	665
SEHI-400	713	874	1009	1128	1236	1335	1427	1514	664	813	939	1050	1150	1242	1328	1408	628	769	888	993	1088	1175	1256	1333

VALVE TYPE	-30°C									-40°C								
	Pressure Drop Across Valve (bar)																	
	4	6	8	10	12	14	16	18	4	6	8	10	12	14	16	18		
SER-B	3.50	4.28	4.94	5.53	6.06	6.54	6.99	7.42	3.27	4.00	4.62	5.17	5.66	6.11	6.54	6.93		
SER-C	9.48	11.6	13.4	15.0	16.4	17.7	19.0	20.1	8.86	10.9	12.5	14.0	15.3	16.6	17.7	18.8		
SER-D	19.3	23.6	27.3	30.5	33.4	36.1	38.6	40.9	18.0	22.1	25.5	28.5	31.2	33.7	36.0	38.2		
SERI-G	38.0	46.6	53.8	60.2	65.9	71.2	76.1	80.7	35.6	43.6	50.4	56.4	61.6	66.6	71.2	75.5		
SERI-J	68.4	83.8	96.8	108	119	128	136	145	64.1	78.5	90.6	101	111	120	128	136		
SERI-K	124	152	176	196	215	232	248	264	116	142	164	184	201	216	232	246		
SERI-L	164	201	232	260	284	307	328	348	153	188	217	243	266	287	307	326		
SEHI-175	295	361	416	466	511	552	589	625	275	338	391	436	478	516	552	585		
SEHI-400	591	724	836	934	1023	1105	1182	1253	552	676	781	873	956	1033	1104	1171		

Liquid Temperature Correction Factors

°F	0	10	20	30	40	50	60	70	80	90	100	110	120	130	140
°C	-18	-12	-7	-1	4	10	16	21	27	32	38	43	49	54	60
R-507A	1.99	1.89	1.79	1.69	1.59	1.50	1.40	1.30	1.20	1.10	1.00	0.89	0.78	0.66	0.51

OFFER OF SALE

The items described in this document and other documents and descriptions provided by Parker Hannifin Corporation, its subsidiaries and its authorized distributors ("Seller") are hereby offered for sale at prices to be established by Seller. This offer and its acceptance by any customer ("Buyer") shall be governed by all of the following Terms and Conditions. Buyer's order for any item described in its document, when communicated to Seller verbally, or in writing, shall constitute acceptance of this offer. All goods or work described will be referred to as "Products".

1. **Terms and Conditions.** Seller's willingness to offer Products, or accept an order for Products, to or from Buyer is expressly conditioned on Buyer's assent to these Terms and Conditions and to the terms and conditions found on-line at www.parker.com/saleterms/. Seller objects to any contrary or additional term or condition of Buyer's order or any other document issued by Buyer.

2. **Price Adjustments: Payments.** Prices stated on the reverse side or preceding pages of this document are valid for 30 days. After 30 days, Seller may change prices to reflect any increase in its costs resulting from state, federal or local legislation, price increases from its suppliers, or any change in the rate, charge, or classification of any carrier. The prices stated on the reverse or preceding pages of this document do not include any sales, use, or other taxes unless so stated specifically. Unless otherwise specified by Seller, all prices are F.O.B. Seller's facility, and payment is due 30 days from the date of invoice. After 30 days, Buyer shall pay interest on any unpaid invoices at the rate of 1.5% per month or the maximum allowable rate under applicable law.

3. **Delivery Dates: Title and Risk: Shipment.** All delivery dates are approximate and Seller shall not be responsible for any damages resulting from any delay. Regardless of the manner of shipment, title to any products and risk of loss or damage shall pass to Buyer upon tender to the carrier at Seller's facility (i.e., when it's on the truck, it's yours). Unless otherwise stated, Seller may exercise its judgment in choosing the carrier and means of delivery. No deferment of shipment at Buyer's request beyond the respective dates indicated will be made except on terms that will indemnify, defend and hold Seller harmless against all loss and additional expense. Buyer shall be responsible for any additional shipping charges incurred by Seller due to Buyer's changes in shipping, product specifications or in accordance with Section 13, herein.

4. **Warranty.** Seller warrants that the Products sold hereunder shall be free from defects in material or workmanship for a period of twelve months from the date of delivery to Buyer or 2,000 hours of normal use, whichever occurs first. This warranty is made only to Buyer and does not extend to anyone to whom Products are sold after purchased from Seller. The prices charged for Seller's products are based upon the exclusive limited warranty stated above, and upon the following disclaimer: **DISCLAIMER OF WARRANTY: THIS WARRANTY COMPRISES THE SOLE AND ENTIRE WARRANTY PERTAINING TO PRODUCTS PROVIDED HEREUNDER. SELLER DISCLAIMS ALL OTHER WARRANTIES, EXPRESS AND IMPLIED, INCLUDING MERCHANTABILITY AND FITNESS FOR A PARTICULAR PURPOSE.**

5. **Claims: Commencement of Actions.** Buyer shall promptly inspect all Products upon delivery. No claims for shortages will be allowed unless reported to the Seller within 10 days of delivery. No other claims against Seller will be allowed unless asserted in writing within 60 days after delivery or, in the case of an alleged breach of warranty, within 30 days after the date within the warranty period on which the defect is or should have been discovered by Buyer. Any action based upon breach of this agreement or upon any other claim arising out of this sale (other than an action by Seller for any amount due to Seller from Buyer) must be commenced within thirteen months from the date of tender of delivery by Seller or, for a cause of action based upon an alleged breach of warranty, within thirteen months from the date within the warranty period on which the defect is or should have been discovered by Buyer.

6. **LIMITATION OF LIABILITY.** UPON NOTIFICATION, SELLER WILL, AT ITS OPTION, REPAIR OR REPLACE A DEFECTIVE PRODUCT, OR REFUND THE PURCHASE PRICE. **IN NO EVENT SHALL SELLER BE LIABLE TO BUYER FOR ANY SPECIAL, INDIRECT, INCIDENTAL OR CONSEQUENTIAL DAMAGES ARISING OUT OF, OR AS THE RESULT OF, THE SALE, DELIVERY, NON-DELIVERY, SERVICING, USE OR LOSS OF USE OF THE PRODUCTS OR ANY PART THEREOF, OR FOR ANY CHARGES OR EXPENSES OF ANY NATURE INCURRED WITHOUT**

SELLER'S WRITTEN CONSENT, EVEN IF SELLER HAS BEEN NEGLIGENT, WHETHER IN CONTRACT, TORT OR OTHER LEGAL THEORY. IN NO EVENT SHALL SELLER'S LIABILITY UNDER ANY CLAIM MADE BY BUYER EXCEED THE PURCHASE PRICE OF THE PRODUCTS.

7. **Contingencies.** Seller shall not be liable for any default or delay in performance if caused by circumstances beyond the reasonable control of Seller.

8. **User Responsibility.** The user, through its own analysis and testing, is solely responsible for making the final selection of the system and Product and assuring that all performance, endurance, maintenance, safety and warning requirements of the application are met. The user must analyze all aspects of the application and follow applicable industry standards and Product information. If Seller provides Product or system options, the user is responsible for determining that such data and specifications are suitable and sufficient for all applications and reasonably foreseeable uses of the Products or systems.

9. **Loss to Buyer's Property.** Any designs, tools, patterns, materials, drawings, confidential information or equipment furnished by Buyer or any other items which become Buyer's property, may be considered obsolete and may be destroyed by Seller after two consecutive years have elapsed without Buyer placing an order for the items which are manufactured using such property. Seller shall not be responsible for any loss or damage to such property while it is in Seller's possession or control.

10. **Special Tooling.** A tooling charge may be imposed for any special tooling, including without limitation, dies, fixtures, molds and patterns, acquired to manufacture Products. Such special tooling shall be and remain Seller's property notwithstanding payment of any charges by Buyer. In no event will Buyer acquire any interest in apparatus belonging to Seller which is utilized in the manufacture of the Products, even if such apparatus has been specially converted or adapted for such manufacture and notwithstanding any charges paid by Buyer. Unless otherwise agreed, Seller shall have the right to alter, discard or otherwise dispose of any special tooling or other property in its sole discretion at any time.

11. **Buyer's Obligation: Rights of Seller.** To secure payment of all sums due or otherwise, Seller shall retain a security interest in the goods delivered and this agreement shall be deemed a Security Agreement under the Uniform Commercial Code. Buyer authorizes Seller as its attorney to execute and file on Buyer's behalf all documents Seller deems necessary to perfect its security interest. Seller shall have a security interest in, and lien upon, any property of Buyer in Seller's possession as security for the payment of any amounts owed to Seller by Buyer.

12. **Improper use and Indemnity.** Buyer shall indemnify, defend, and hold Seller harmless from any claim, liability, damages, lawsuits, and costs (including attorney fees), whether for personal injury, property damage, patent, trademark or copyright infringement or any other claim, brought by or incurred by Buyer, Buyer's employees, or any other person, arising out of: (a) improper selection, improper application or other misuse of Products purchased by Buyer from Seller; (b) any act or omission, negligent or otherwise, of Buyer; (c) Seller's use of patterns, plans, drawings, or specifications furnished by Buyer to manufacture Product; or (d) Buyer's failure to comply with these terms and conditions. Seller shall not indemnify Buyer under any circumstance except as otherwise provided.

13. **Cancellations and Changes.** Orders shall not be subject to cancellation or change by Buyer for any reason, except with Seller's written consent and upon terms that will indemnify, defend and hold Seller harmless against all direct, incidental and consequential loss or damage. Seller may change product features, specifications, designs and availability with notice to Buyer.

14. **Limitation on Assignment.** Buyer may not assign its rights or obligations under this agreement without the prior written consent of Seller.

15. **Entire Agreement.** This agreement contains the entire agreement between the Buyer and Seller and constitutes the final, complete and exclusive expression

of the terms of the agreement. All prior or contemporaneous written or oral agreements or negotiations with respect to the subject matter are herein merged.

16. **Waiver and Severability.** Failure to enforce any provision of this agreement will not waive that provision nor will any such failure prejudice Seller's right to enforce that provision in the future. Invalidation of any provision of this agreement by legislation or other rule of law shall not invalidate any other provision herein. The remaining provisions of this agreement will remain in full force and effect.

17. **Termination.** This agreement may be terminated by Seller for any reason and at any time by giving Buyer thirty (30) days written notice of termination. In addition, Seller may by written notice immediately terminate this agreement for the following: (a) Buyer commits a breach of any provision of this agreement (b) the appointment of a trustee, receiver or custodian for all or any part of Buyer's property (c) the filing of a petition for relief in bankruptcy of the other Party on its own behalf, or by a third party (d) an assignment for the benefit of creditors, or (e) the dissolution or liquidation of the Buyer.

18. **Governing Law.** This agreement and the sale and delivery of all Products hereunder shall be deemed to have taken place in and shall be governed and construed in accordance with the laws of the State of Ohio, as applicable to contracts executed and wholly performed therein and without regard to conflicts of laws principles. Buyer irrevocably agrees and consents to the exclusive jurisdiction and venue of the courts of Cuyahoga County, Ohio with respect to any dispute, controversy or claim arising out of or relating to this agreement. Disputes between the parties shall not be settled by arbitration unless, after a dispute has arisen, both parties expressly agree in writing to arbitrate the dispute.

19. **Indemnity for Infringement of Intellectual Property Rights.** Seller shall have no liability for infringement of any patents, trademarks, copyrights, trade dress, trade secrets or similar rights except as provided in this Section. Seller will defend and indemnify Buyer against allegations of infringement of U.S. patents, U.S. trademarks, copyrights, trade dress and trade secrets ("Intellectual Property Rights"). Seller will defend at its expense and will pay the cost of any settlement or damages awarded in an action brought against Buyer based on an allegation that a Product sold pursuant to this Agreement infringes the Intellectual Property Rights of a third party. Seller's obligation to defend and indemnify Buyer is contingent on Buyer notifying Seller within ten (10) days after Buyer becomes aware of such allegations of infringement, and Seller having sole control over the defense of any allegations or actions including all negotiations for settlement or compromise. If a Product is subject to a claim that it infringes the Intellectual Property Rights of a third party, Seller may, at its sole expense and option, procure for Buyer the right to continue using the Product, replace or modify the Product so as to make it noninfringing, or offer to accept return of the Product and return the purchase price less a reasonable allowance for depreciation. Notwithstanding the foregoing, Seller shall have no liability for claims of infringement based on information provided by Buyer, or directed to Products delivered hereunder for which the designs are specified in whole or part by Buyer, or infringements resulting from the modification, combination or use in a system of any Product sold hereunder. The foregoing provisions of this Section shall constitute Seller's sole and exclusive liability and Buyer's sole and exclusive remedy for infringement of Intellectual Property Rights.

20. **Taxes.** Unless otherwise indicated, all prices and charges are exclusive of excise, sales, use, property, occupational or like taxes which may be imposed by any taxing authority upon the manufacture, sale or delivery of Products.

21. **Equal Opportunity Clause.** For the performance of government contracts and where dollar value of the Products exceed \$10,000, the equal employment opportunity clauses in Executive Order 11246, VEVRRA, and 41 C.F.R. §§ 60-1.4(a), 60-741.5(a), and 60-250.4, are hereby incorporated.



Parker Hannifin Corporation

Sporlan Division

206 Lange Drive • Washington, MO 63090 USA

phone 636 239 1111 • fax 636 239 9130

www.sporlan.com